

JUWEL PLUS Digital calipers

In stainless steel, tempered - Accuracy DIN 862
 With $\frac{1}{100}$ mm (0,01 mm) graduation - .0005 inches
 Highest level of accuracy, even at high speed sliding movements
 Jaws with tips for measuring small grooves and slots
 Screw locking and individual identification number
 Individually checked and tested - Supplied with case

Type with fixed glass rail for a more accurate repetitiveness

With protection level IP 54 against dust and water splashes

ON/OFF, ABS/INC, ZERO and mm/inch functions

Wide, 5-digit 9 mm display

Measuring range	mm	150	200	300
Code		H 4216 8150	H 4216 8200	H 4216 8300
H 4216/8	Each €			
Jaw length	mm	40	50	60
Accuracy	$\pm \mu\text{m}$	0,02	0,03	0,03



JUWEL PLUS Depth base attachment

In stainless steel - With locking screw

Suitable for calipers with measuring range up to 200 mm - Base width 75 mm

Code H 4217 0000	H 4217	Each €	1
------------------	--------	--------	---



JUWEL PLUS Workshop vernier calipers

In stainless steel, tempered and ground - Accuracy DIN 862

$\frac{1}{50}$ mm (0,02 mm) graduation

Single-piece vernier scale - Lapped tips - Rounded lower jaws

Matt chromed scale and vernier scale

Lower jaws for inside measurements ≥ 10 mm (2x5 mm)

With locking screw, **micrometric regulation** and

individual identification number

Individually checked and tested - Supplied with case

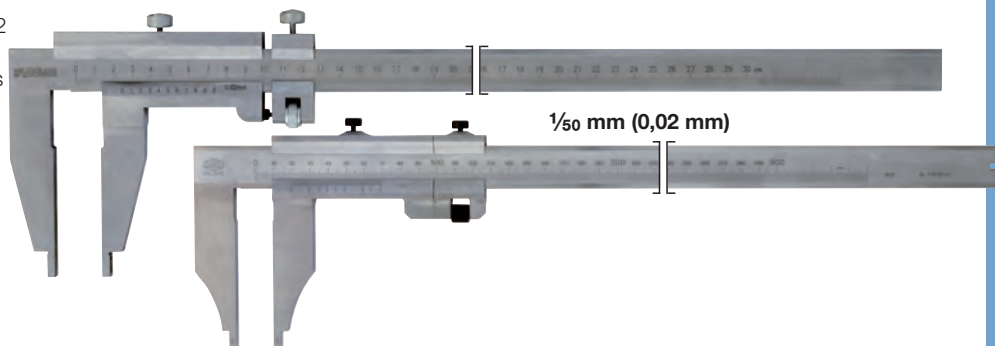

Type without upper jaws

H 4219 - ~~ABC~~

H 4220 -

Measuring range	mm	200	250	300	400	500	600	800	1000
Code		—	—	H 4219 0300	—	—	—	—	—
H 4219	Each €								
Code		H 4220 0200	H 4220 0250	H 4220 0300	H 4220 0400	H 4220 0500	H 4220 0600	H 4220 0800	H 4220 1000
H 4220	Each €								
Jaw lengths H 4219	mm	—	—	90	—	—	—	—	—
Jaw lengths H 4220	mm	65	80	90	90	115	115	150	150

Type with upper jaws

H 4221 - With upper jaws for outside measurements

H 4222 - With lower jaws for inside measurements

Measuring range	mm	200	300	500
Code		—	H 4221 0300	H 4221 0500
H 4221	Each €			
Code		H 4222 0200	H 4222 0300	H 4222 0500
H 4222	Each €			

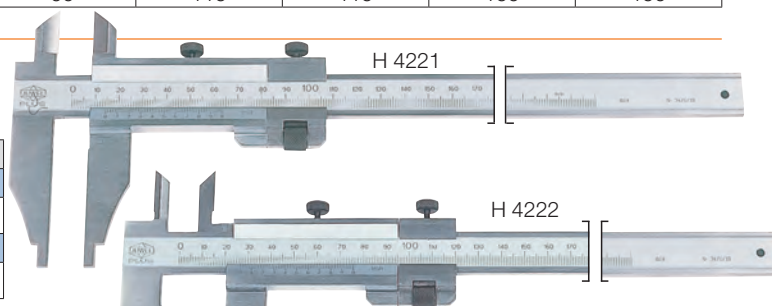

Digital type

With $\frac{1}{100}$ mm (0,01 mm) graduation - .0005 inches

Lower jaws for inside measurements ≥ 20 mm (2x10 mm)

Prepared for data output and automatic switch-off

ON/OFF, ABS/INC, ZERO and mm/inch functions

Wide, easy to read, 5-digit display - SR-44 battery powered

H 4225 - With upper jaws for outside measurements

H 4226 - With lower jaws for inside measurements

Measuring range	mm	300	500	1000
Code		H 4225 0300	H 4225 0500	H 4225 1000
H 4225	Each €			
Code		H 4226 0300	H 4226 0500	—
H 4226	Each €			
Jaw length	mm	100	150	200
Weight	kg	0,6	1,1	2,5

