

ABC TOOLS Pipe die stocks

In pressed steel

For threading and finishing bolts, stud bolts, etc.

With 2 fixing screws and pin

Suitable for mounting **two dies** of different dimensions, one on each end

Size		1	2	3
Code		F 7984 0001	F 7984 0002	F 7984 0003
F 7984	Each €			
For dies Ø	mm	20 and 25	25 and 38	38 and 50,8
External Ø	mm	34	34 and 48	48 and 60
Overall length	mm	160	190	215

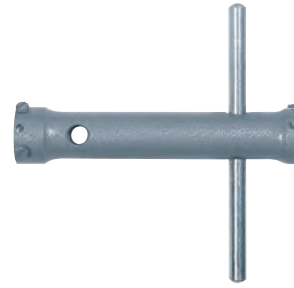

T-handle tap wrenches

Two jaws, for right/left-hand, fixed operation - Ideal to work in hard-to-reach places

Handy and sturdy for multi-purpose use with taps, reamers, etc.

Chromed version - With sliding handle

KUNZ - Precision version in steel

F 7986/1 - Short version

F 7986/2 - Long version

Size		0	1	2	3
Code		F 7986 1000	F 7986 1001	F 7986 1002	F 7986 1003
F 7986/1	Each €				
Code		—	F 7986 2001	F 7986 2002	—
F 7986/2	Each €				
For tools with ■ drive	mm	1÷2,6	2÷5	4,6÷8	9÷12,5
Suitable for taps	M	1÷2,6	3÷8	5÷12	13÷20
Overall length mm F 7986/1		85	85	110	117
Overall length mm F 7986/2		—	250	315	—

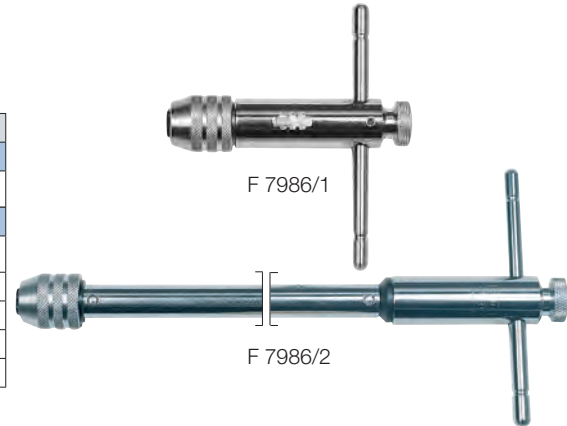

Pair of spare jaws with spring

For T-handle tap wrench	size	1	2
Code		F 7987 0001	F 7987 0002
F 7987	Per pair €		



ABC TOOLS

External steel body, zinc die casting internal components

Size		1	2
Code		F 7988 1001	F 7988 1002
F 7988/1	Each €		
For ■ drive tools	mm	2,4÷5,5	4,5÷7
Suitable for taps	M	3÷10	5÷12
Overall length	mm	85	110



Pair of spare jaws with spring

For T-handle tap wrench	size	1	2
Code		F 7989 0001	F 7989 0002
F 7989	Per pair €		



ABC TOOLS Fixed T-handle tap wrenches

«Goodell» model

With 4 jaws - **With simple chuck**

F 7991/1 - Short version

F 7991/11 - Medium version - Overall length 150 mm

F 7991/2 - Long version - Overall length 200 mm

Size		0	1	2	3	4
Code		F 7991 1000	F 7991 1001	F 7991 1002	F 7991 1003	F 7991 1004
F 7991/1	Each €					
Code		—	F 7991 1101	F 7991 1102	F 7991 1103	F 7991 1104
F 7991/11	Each €					
Code		—	F 7991 2001	F 7991 2002	F 7991 2003	F 7991 2004
F 7991/2	Each €					
For tools with ■ drive	mm	0,5÷2	2,2÷4	3÷5	5÷7	6÷8
Overall length mm F 7991/1		60	80	90	100	100
	pcs.	10	10	10	10	10

