

ABC TOOLS Internal and external pullers

Hot-forged steel - Zinc-chrome version

Suitable for internal (dimension «a») and external - Extra-strong cross-bar with "T" profile

Reversible interchangeable arms, sliding on ground guides that ensure parallel traction

For medium depth extraction

Pullers with 2 arms

Cross-bar with centimeter scale for uniform regulation of the opening of the arms

Max. opening "a" mm	90	130	160	200	250	350	520
Code C 3323 ...	1090	1130	1160	1200	1250	1350	1520
C 3323/1 Each €							
Working length of hooks ℓ mm	100	100	150	150	200	200	200
Max. pressure t	3	3	5	5	7,5	7,5	10
Screw thread	M14x1,5	M14x1,5	G 1/2"	G 1/2"	G 3/4"	G 3/4"	G 1"

Puller with 3 arms - Particularly suitable for applying large forces

Max. opening "a" mm	90	130	160	200	250
Code C 3323 1109	C 3323 1109	C 3323 1113	C 3323 1116	C 3323 1120	C 3323 1125
C 3323/11 Each €					
Working length of hooks ℓ mm	100	100	100	150	200
Max. pressure t	3	3	3,5	5	7,5
Screw thread	M14x1,5	M14x1,5	G 1/2"	G 1/2"	G 3/4"

Set of 5 pullers with support C 3323/1 max. opening 90 - 130 - 160 - 200 - 250 mm

Code C 3323 9000	C 3323/9	Each €	 1
------------------	-----------------	--------	---

For deep extraction - With 2 arms

Cross-bar with centimeter scale for uniform regulation of the opening of the arms

C 3323/2 - Working length of the arms ℓ 200 mm

C 3323/3 - Working length of the arms ℓ 300 mm

C 3323/4 - Working length of the arms ℓ 400 mm

C 3323/5 - Working length of the arms ℓ 500 mm

Max. opening "a" mm	90	130	160	200
Code C 3323 2090	C 3323 2090	C 3323 2130	—	—
C 3323/2 Each €				
Code	—	—	C 3323 3160	C 3323 3200
C 3323/3 Each €				
Max. pressure mm	3	3	5	5
Screw thread x length mm	M 14x1,5x140	M 14x1,5x140	G 1/2"x210	G 1/2"x210
Max. opening "a" mm	250	350	520	
Code C 3323 3250	C 3323 3250	C 3323 3350	C 3323 3520	
C 3323/3 Each €				
Code C 3323 4250	C 3323 4250	C 3323 4350	C 3323 4520	
C 3323/4 Each €				
Code	—	C 3323 5350	C 3323 5520	
C 3323/5 Each €				
Max. pressure t	7,5	7,5	10	
Screw thread x length mm	G 3/4"x280	G 3/4"x280	G 1"x310	

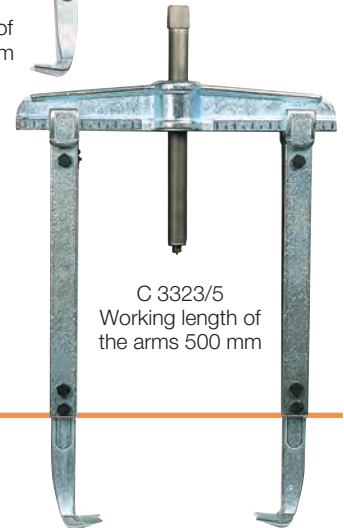
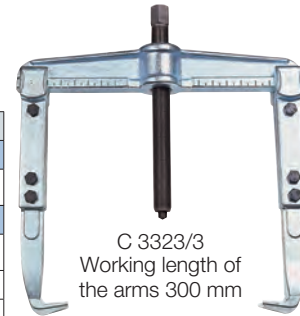
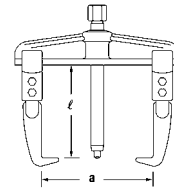

ABC TOOLS Screws for pullers

Suitable for replacing the screws in any puller with the threads indicated in the table

Normal version

Screw thread	M14x1,5	G 1/2"	G 3/4"	G 1"
Code C 3323 9501	C 3323 9501	C 3323 9502	C 3323 9503	C 3323 9504
C 3323/95 Each €				
Overall length mm	140	210	280	310

Hydraulic type

Make it possible to increase the force normally applied by at least 50%, reducing the force and working faster - Hydraulic spindle range 12 mm

Screw thread	G	1/2"	3/4"	1"
Code C 3328 1012	C 3328 1012	C 3328 1034	C 3328 1001	
C 3328/1 Each €				
Max. pressure t	10	12	15	
Overall length mm	350	420	465	

